

vector kites by premier designs

RC BUTTERFLY

premierrc.com

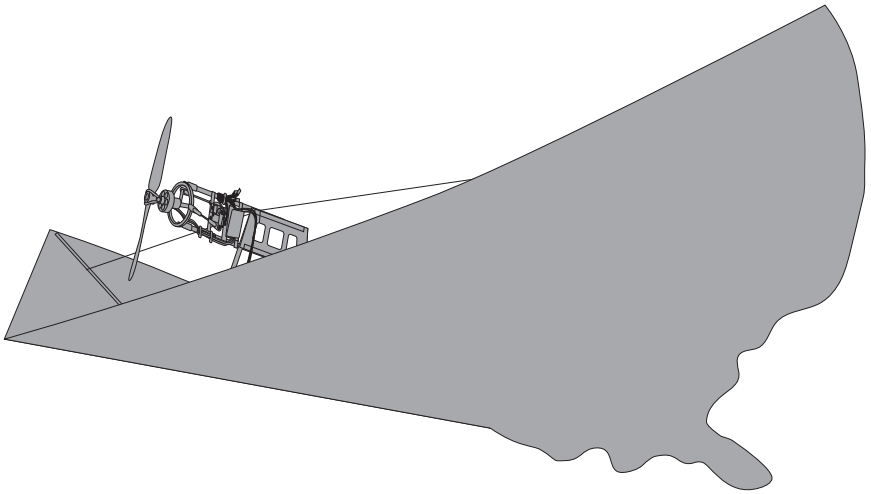

Congratulations!

Welcome to the world of Vector Kite Flying. Keep in mind that you are now one of the first pioneers of this exciting new RC sport. Vector Kite Flying offers you new challenges and excitement not found in any other form of model aviation. With the Premier Gimbal System (patent pending) installed in a Vector-Ready Kite, you will discover an exhilarating dimension between the beauty and gracefulness of traditional kite flying with the art of piloting remote aircraft.

If you have any questions or want to learn more about Vector Kites, please see us on the web at www.premierRC.com

Sincerely,

The Staff at Premier Kites

Names of Parts

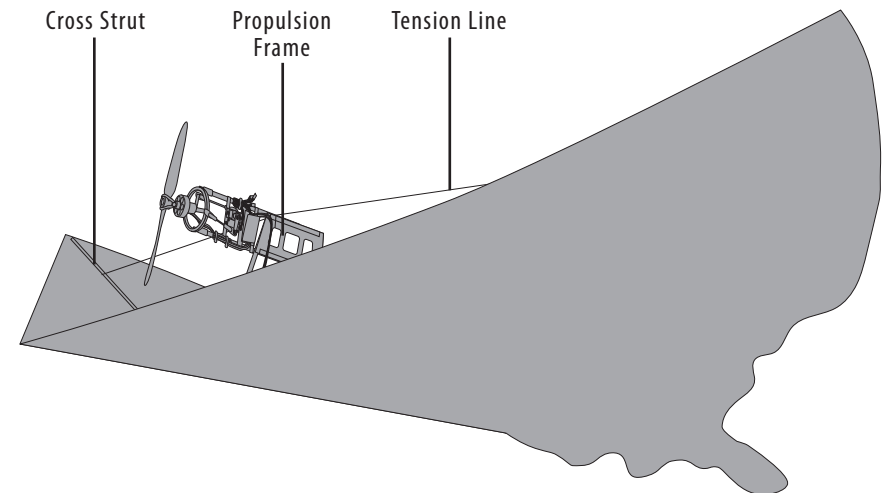

WARNING – SAFETY FIRST

Radio controlled kites can be very dangerous if used improperly. The kite and propeller travel at very high speeds and can cause serious injuries to the flyers and other persons nearby. Never fly the radio controlled kites near or over people, roadways, airports or electrical lines. PremierRC.com does not assume any legal responsibilities for personal injuries of any kind or for property damages caused while flying radio controlled kites.

PremierRC.com Hyattsville, MD, USA 20781 Made in China Patent Pending

Kite Assembly Instructions

1

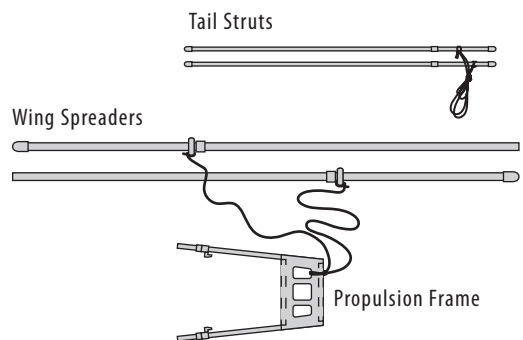
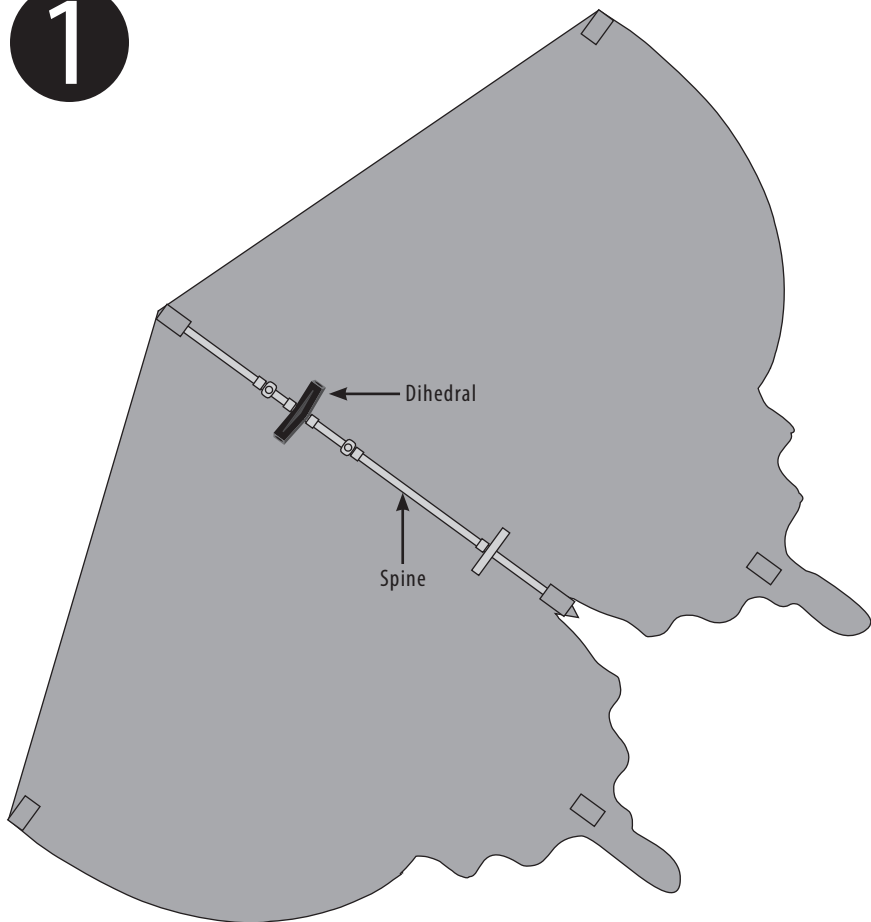

Unroll the kite so it is face down on the ground. Set aside and identify the struts.

2

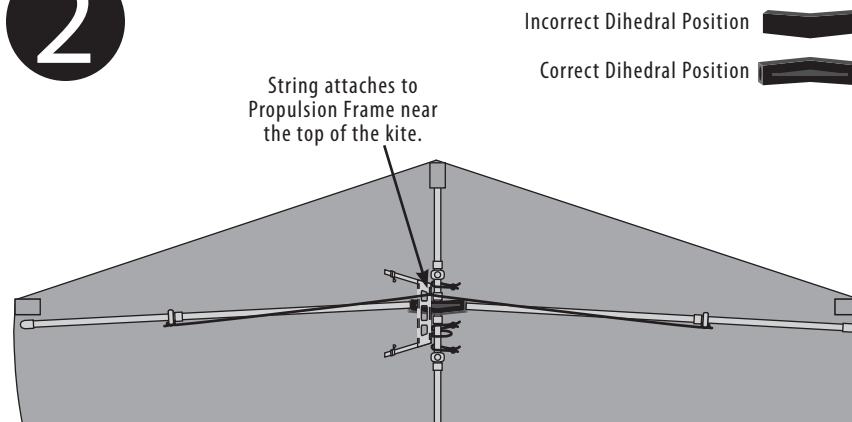

Position the Propulsion Frame over the Spine so that the Tenion Line is towards the top of the kite. Insert the uncapped ends of the Cross Struts into the Dihedral. Make sure the tip (bottom of the 'V') of the Dihedral is pointing towards the front of the kite.

3

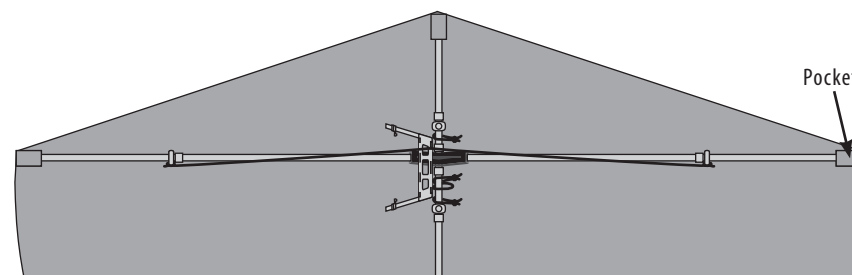

Insert the end capped end of the Cross Struts into the Pockets.

4

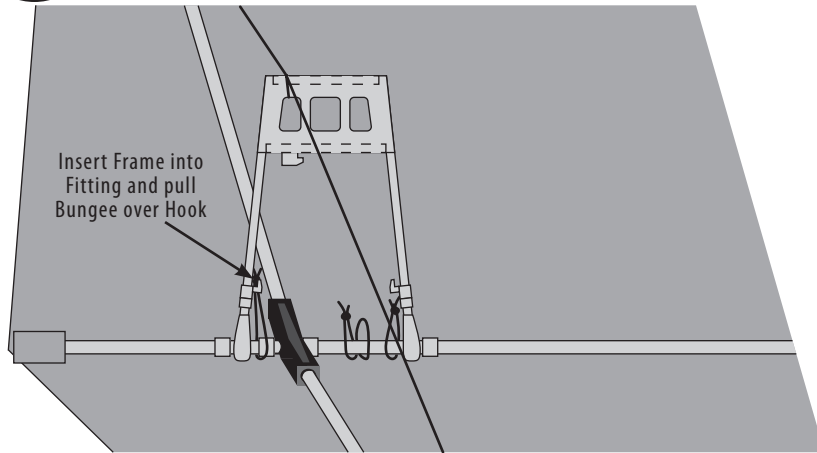

Insert the Propulsion Frame Struts into the Fittings on the Spine. Make sure all Bungees are between the fittings. Pull the two shorter Bungees over the Hooks on the Propulsion Frame.

6

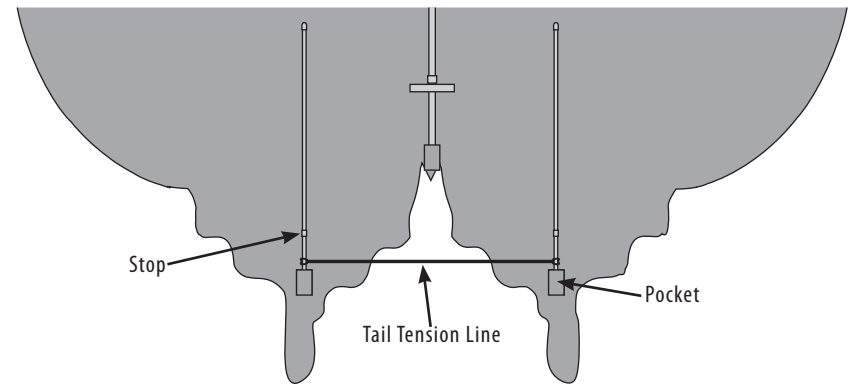

Insert the end of the Tail Struts with the Stop into the Tail Pockets. Make sure the Tail Tension Line is below the Stop.

5

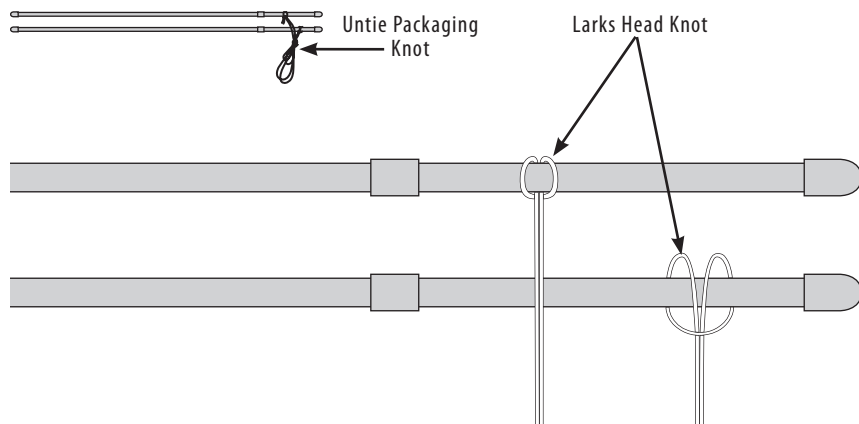

Untie the large knot in the string connecting the Tail Struts. Keep the ends attached to the Struts with a Larks Head Knot.

7

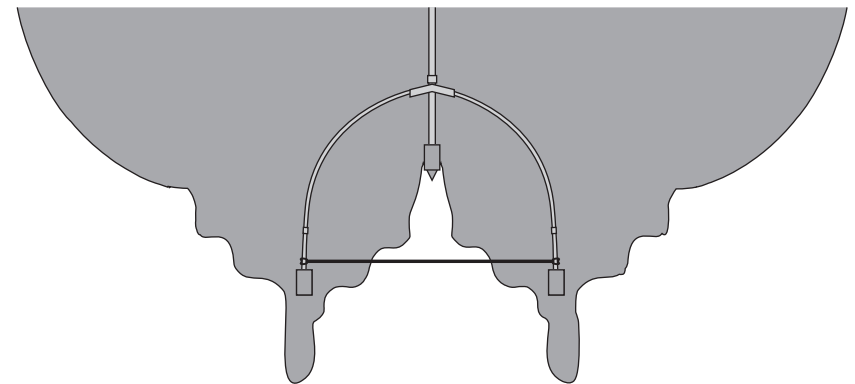

Carefully bend the Tail Struts and insert the remaining ends into the Tail Strut Tube along the Spine. Push ends all the way into the center of the tube.

RC Flight Instructions

Step 1: Getting Started

Your Vector Powered Kite is composed of four main components:

- 1.) The Vector Ready Kite
- 2.) The Vector Power Unit (purchased separately)
- 3.) Vector Power Unit Batteries (purchased separately)
- 4.) The Transmitter Receiver (purchased separately)

The **Vector Ready Kite (VR)** is a high quality aircraft that is built with rip-stop nylon sails, and fiberglass and/or carbon framing material. A Vector Ready kite includes a specially built Propulsion Frame to receive the Vector Power Unit. Also included are provisions to mount the LiPo battery pack. All Vector Ready Kites include a high quality case to store your kite.

The **Vector Power Unit** is what powers and controls your Vector Kite. The 840 Vector Power Unit is purchased with a foam protection case and includes two propellers (one is a spare), prop-saver, prop wrench and instruction manual. We recommend you store your Power Unit in the protective foam case to protect its mechanical components.

Vector Power Unit Batteries for the 840 Vector Power Unit are sold separately. For the 840 Vector Power Unit only a high quality lithium polymer (LiPo) battery is recommended with the following specifications:

Battery Type: Lithium Polymer
Capacity: 750 mA to 1200 mA
Volts: 12.6 (max) 11.25 (min)
Cell #: 3 - All cells in series (3S1P)
Discharge "C" rating: 15c to 20c is good. Please note higher "C" ratings such as 40 and above can cause motor damage at full throttle discharge.

High quality LiPo batteries are available at your local hobby shop or can be found on many hobby web shops. Batteries are also available from Premier RC at www.premierRC.com

Please note the 840 Vector Power Unit is fitted with a standard XT60 connection plug. Although this is a common and reliable battery connection plug, it is up to the owner to decide which battery connection plug he or she wishes to use.

Please also note that battery charges are sold separately. Please only use a high quality battery charger designed for LiPo batteries and follow all precautions from the manufacturer. Please read the Safety Section on pages 10 and 11 of this manual.

The **Transmitter/Receiver** is what links the pilot to the Vector Kite. There are many fine brands of transmitter/receiver products available at your local hobby shop or hobby web shop. Premier RC encourages pilots to use the brand they are most comfortable with. A basic Vector Kite set-up only requires three channels: THROTTLE (proportional), LEFT-RIGHT servo (typically aileron) and an UP-DOWN servo (typically elevator). A simple transmitter is also available from www.premierRC.com.

8

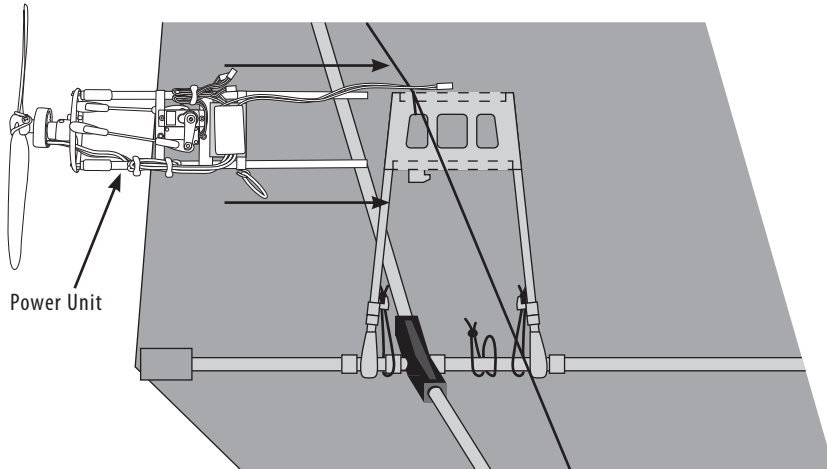

Slide the Power Unit all the way into the Propulsion Frame. Make sure the O-ring on the Power Unit is on the bottom.

9

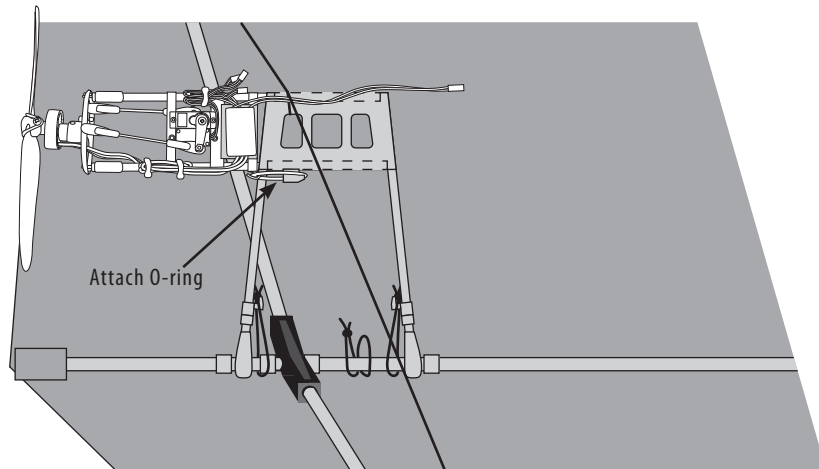

Attach the O-ring on the Power Unit to the hook on the Propulsion Frame.

STEP 2: Battery Charging

Please note that the Model 840 Vector Power Unit does not include a battery or battery charger. Many high quality LiPo battery chargers are available at your local hobby shop or hobby web shop. If you wish, you may purchase batteries and a simple charger directly from Premier RC at www.premierRC.com

LiPo Battery Safety:

- **Always** use the recommended chargers specifically approved for use with your Lithium Polymer cells or packs when charging. If you do not, personal harm and/or property damage may occur.
- **Always** test your charger to assure it is functioning properly.
- **Always** charge your Lithium Polymer cells on concrete at least 10 feet (3 meters) from any combustible materials. NEVER leave the charger unattended while batteries are connected!
- **Always** store Lithium Polymer cells or packs in a fireproof container.
- **Always** have sand or dry fire extinguisher handy in the event of fire.
- **Always** keep all batteries out of the reach of children and animals.
- **Always** observe the correct polarity when connecting cells or packs to charger or application.
- **Always** seek medical attention if electrolyte gets in your eyes (flush with cold water immediately).
- **Always** scrub with soap and water if electrolyte comes in contact with your skin.

Safe Handling:

- **Never** charge Lithium Polymer cells or packs unattended.
- **Never** charge Lithium Polymer beyond factory specifications. This is highly dangerous and strictly prohibited.
- **Never** exceed the factories maximum allowed charge and discharge rates.
- **Never** charge Lithium Polymer in contained areas where damage may occur (car, home, garage, etc.)
- **Never** charge Lithium Polymer while in the application as the hot pack may ignite certain materials.
- **Never** charge Lithium Polymer on flammable materials such as wood, foam or plastic.
- **Never** extinguish a Lithium Polymer fire with water.
- **Never** disassemble a Lithium Polymer cell or pack.
- **Never** short circuit Lithium Polymer cells or packs.
- **Never** use a Lithium Polymer cell or pack that has been damaged.
- **Never** store a Lithium Polymer cell or pack in your pocket, purse, bag, desk drawer, etc.
- **Never** keep cells or packs in temperatures that exceed 60C/140F.
- **Never** combine different cell sizes or capacities together in the same pack.
- **Never** continue to drain the battery after you are out of power to fly.

Damaged Battery Packs:

- Before each use safely and carefully inspect the cells, wire leads and all connections for any possible short circuiting.
- If there is any doubt about short circuiting to the cell or pack, safely cut all wires from the pack completely.
- If any cells are dented, deformed or damaged in any way do not use the pack.
- If any cells or packs become damaged, follow the disposal notes below.

Disposal of Battery Packs:

- If the Lithium Polymer pack **IS** damaged, immerse it in salt water for a minimum of two weeks to discharge the battery pack.
 - Use ½ cup of salt per gallon of water.
 - Use cold water and a plastic container. Never use a metal container.
- If the Lithium Polymer pack is **NOT** damaged, discharge it to 1V per cell.
 - (2S pack = 2V, 3S pack = 3V).
 - You may use a 150 ohm 2W resistor to discharge,
OR... Connect it to the device and run it until the discharge voltage is observed.
- Apply tape over **ALL** electrical terminals or exposed wires.
- Lithium Polymer batteries are environmentally safe for landfill disposal.

ALWAYS FOLLOW ALL SAFETY DIRECTIONS TO PREVENT ACCIDENTS OR DAMAGE TO PERSONS OR PROPERTY.

Using the Optional Premier RC Charger:

WARNING: THE LITHIUM POLYMER BATTERIES THAT COME WITH YOUR VECTOR KITE ARE DIFFERENT FROM OTHER COMMON BATTERIES SUCH AS AKALINE, NiCad or ZINC CARBON AND REQUIRE SPECIAL PRECAUTIONS. PLEASE READ THE ATTACHED BATTERY PRECAUTION INFORMATION.

1. Plug in the battery charger to a normal household 120V socket.
2. Connect the four conductor white plug on the battery to the four conductor socket on the battery charger.
3. Follow the instructions on the charger. When the LED light is "green" the battery is charged. Charging takes about 20 minutes.
4. NEVER, NEVER, NEVER leave a battery unattended while charging. Monitor charging batteries at all times. Only charge batteries on a non-flammable surface. READ ALL BATTERY PRECAUTIONS.

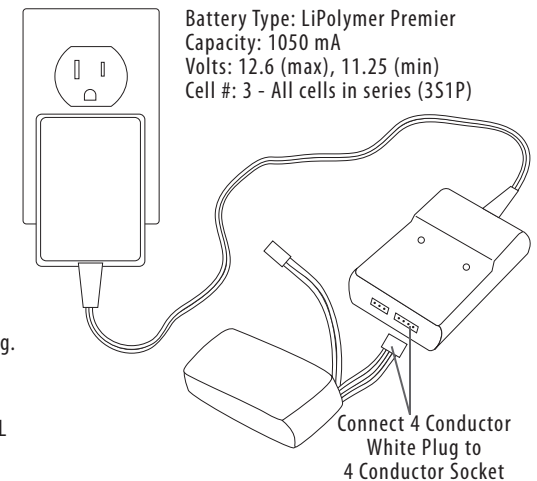

WARNING: LITHIUM-POLYMER BATTERIES ABSOLUTELY MUST ALWAYS BE HANDLED WITH EXTREME CAUTION. THEY ARE DIFFERENT THAN NICD AND NIMH BATTERIES. PREMIERRC WILL NOT BE HELD RESPONSIBLE FOR ANY AND ALL INCIDENTAL DAMAGES AND BODILY HARM THAT MAY RESULT FROM IMPROPER USE OF PREMIERRC BRAND LIPO BATTERIES. IN PURCHASING THESE PRODUCTS, THE BUYER/USER AGREES TO BEAR ALL RESPONSIBILITIES OF THESE RISKS AND NOT HOLD PREMIERRC AND/OR ITS DISTRIBUTORS (OWNERS AND EMPLOYEES) RESPONSIBLE FOR ANY ACCIDENTS, INJURY TO PERSONS, OR PROPERTY DAMAGE. IF YOU DO NOT AGREE WITH THESE CONDITIONS, PLEASE RETURN THE BATTERY TO THE PLACE OF PURCHASE.

STEP 3: Receiver & Antenna Installation

NOTE: MANY DIFFERENT STYLES OF RECEIVERS CAN MOUNT ON YOUR 840 VECTOR POWER UNIT. THE MOST COMMON WAY TO MOUNT THE RECEIVER TO THE POWER UNIT IS BY USING VELCRO.

1. Adhere the 'soft' side of a small Velcro patch to the back of the receiver.
2. Mount the receiver to the panel of 'hook' side Velcro installed on the Power Unit.
3. Plug ESC and Servos into their proper receiver ports (see diagram).

IMPORTANT: ALWAYS MAKE SURE YOUR ANTENNA IS WELL CLEAR OF ALL PROPELLER POSITIONS WHEN GIMBAL IS OPERATED!

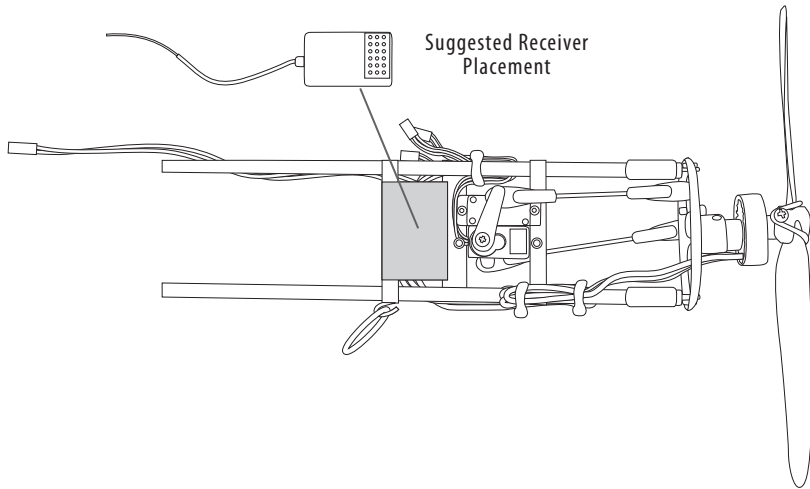

Typical Receiver (Manufacturers may vary, consult your Transmitter/Receiver Owners Manual)

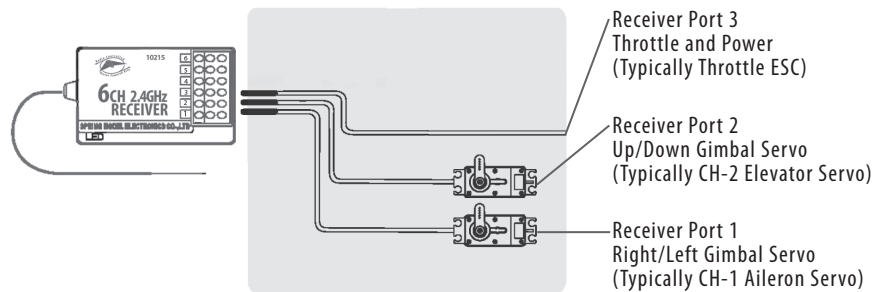

STEP 4: Transmitter Power-Up & Battery Installation

IMPORTANT: ALWAYS TURN TRANSMITTER "ON" FIRST BEFORE POWERING UP VECTOR KITE™. ALWAYS DE-POWER VECTOR KITE™ BEFORE TURNING TRANSMITTER OFF.

1. Make sure throttle control is all the way back (down). Make sure all trim controls are in the middle position.
2. Turn the transmitter on.

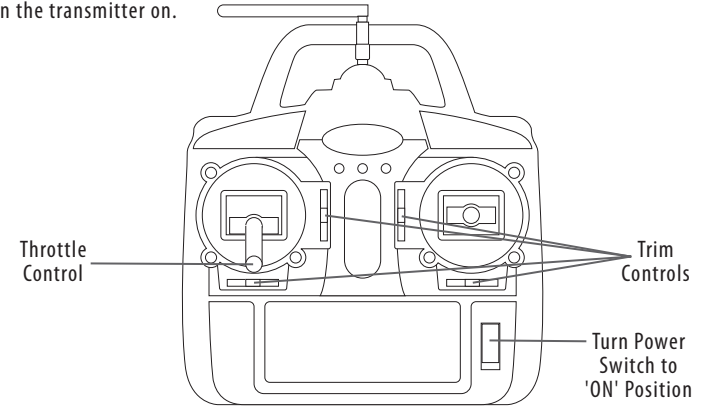

3. Plug in battery to Vector Kite.™

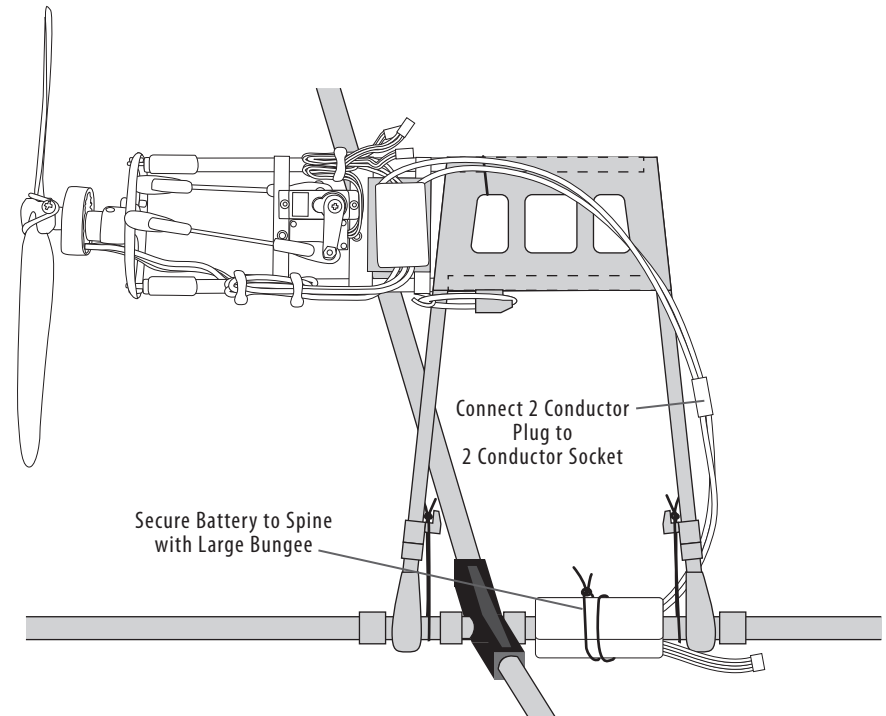

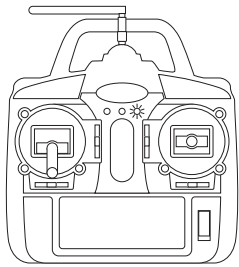

Right Control Stick in **Neutral**

Propeller Aligned **Straight**

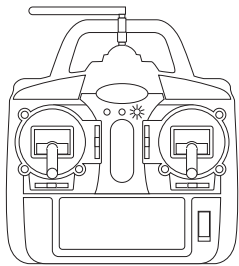
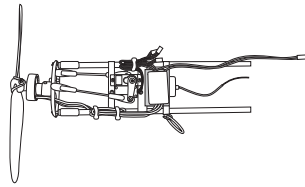

Right Control Stick Pointing **Back**

Propeller Turns **Up**

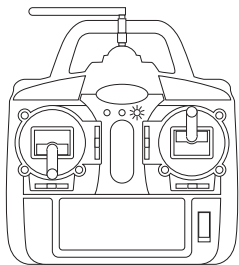
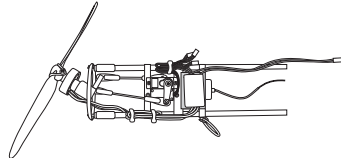

Right Control Stick Pointing **Forward**

Propeller Turns **Down**

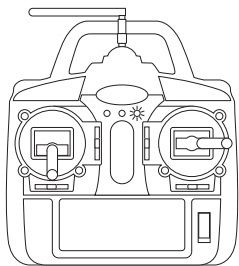
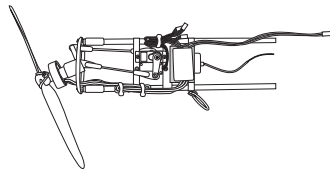

Right Control Stick Pointing **Right**

Propeller Turns **Right**

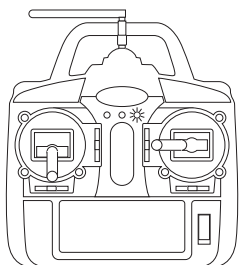
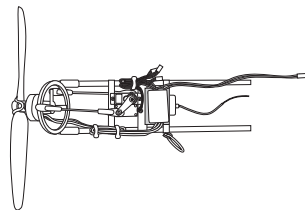

Right Control Stick Pointing **Left**

Propeller Turns **Left**

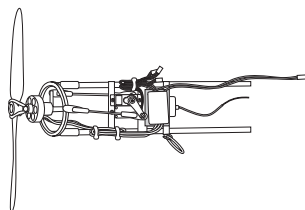

STEP 5: Control Test

1. Follow the diagrams on the opposite page to make sure the controls function per the illustrations.

STEP 6: Servo Reversing & Changing Servo Arm Positions

NOTE: MOST TRANSMITTERS INCLUDE SERVO REVERSING SWITCHES. THESE ARE USUALLY LOCATED ON THE FRONT OF THE TRANSMITTER OR IN THE BATTERY COMPARTMENT OF YOUR TRANSMITTER (PLEASE CONSULT YOUR MANUFACTURER'S MANUAL). IF YOUR CONTROLS WORK OPPOSITE THAN THE ILLUSTRATIONS OR IF YOU PREFER OPPOSITE STICK CONTROL THAN WHAT IS ILLUSTRATED, YOU MAY CHANGE THE SWITCH POSITIONS.

NOTE: ON THE VECTOR POWER UNIT YOUR SERVOS COME FACTORY ADJUSTED TO THE CORRECT TRIM POSITION. IF YOU NEED TO ADJUST THE TRIM POSITION OF EITHER THE UP-DOWN SERVO OR LEFT-RIGHT SERVO THERE ARE TWO METHODS AVAILABLE.

1. **ELECTRONIC METHOD** – The electronic method is the easiest way to adjust the trim on the servo. Most transmitters include trim adjustment controls located on either side of the control sticks. You may read more about these adjustments in "STEP 11: TRIM ADJUSTMENTS". Some transmitters include programmable trim and servo adjustments. Please consult your transmitter manual.
2. **MECHANICAL METHOD** – The mechanical method is done by unscrewing the servo arm release screw, pulling off the servo arm and repositioning the servo arm to the desired spot. In general, when the gimbal is in neutral position, the servo arm should be at about a 90° angle to the servo (see diagram). Neutral position is defined when the gimbal is adjusted so the motor axle runs parallel to the GEN II frame when looked at from both a top view and a side view. Mechanical adjustments should only be made if large changes are needed in the servo control arms.

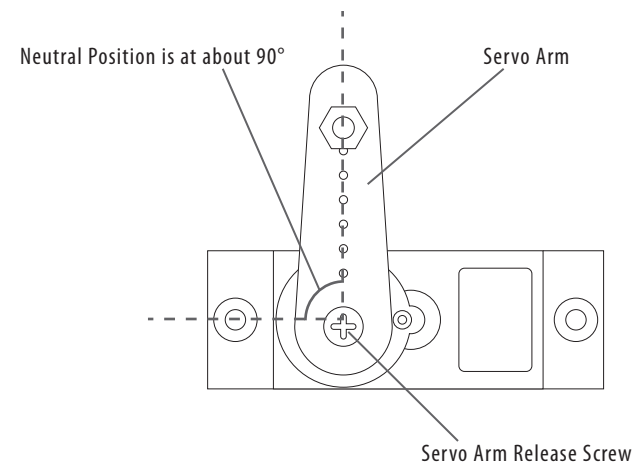

STEP 7: Field Conditions

IMPORTANT: ON YOUR FIRST FLIGHTS, CHOOSE A DAY WITH NO WIND. THE CALMER THE WIND THE BETTER FOR LEARNING TO CONTROL YOUR VECTOR KITE. REMEMBER, FLYING IN WIND IS BY FAR THE NUMBER ONE CAUSE FOR CRASHES FOR BEGINNER VECTOR KITE™ PILOTS.

IMPORTANT: CHOOSE A LARGE FIELD FOR YOUR FIRST FLIGHTS. THE FIELD SHOULD HAVE A MINIMUM OF 300 FEET IN ALL DIRECTIONS FROM THE PILOT.

IMPORTANT: NEVER FLY OVER OR NEAR PEOPLE, BUILDINGS, POWER LINES, HIGHWAYS, TRAIN TRACKS, MOTOR VEHICLES, TREES, HARD SURFACES, WATER AND/OR ANYTHING THAT YOU COULD CRASH INTO AND CAUSE HARM, INJURY OR DAMAGE TO YOU, YOUR VECTOR KITE™ AND/OR OTHERS. PLEASE TAKE THIS WARNING SERIOUSLY.

IMPORTANT: DO NOT ATTEMPT TO FLY INDOORS, SUCH AS IN A GYM, UNTIL YOU HAVE FULLY MASTERED CONTROL OF YOUR VECTOR KITE™. DO NOT FLY INDOORS WITH PEOPLE IN THE INDOOR AREA.

1. Although you are anxious to fly your Vector Kite™, it is important to wait for a calm day. Remember, Vector Kites™ are the “grandchildren” of traditional kites. They are still very much affected by the wind. Wind is a variable you can do without while learning. For beginners, it is the number one cause for crashes. Once you become familiar flying your Vector Kite™, a little wind can be fun to play with but for initial training, pick a calm day. Grab some grass and throw it in the air. The grass should almost drop straight to the ground. You should not feel wind on any part of your body. If you see leaves moving in trees, it is best to wait for another day.
2. Pick a large field. You will want something the size of a football field or two soccer fields. Make sure it is free from obstacles such as buildings or trees. Do not fly near people or vehicles.

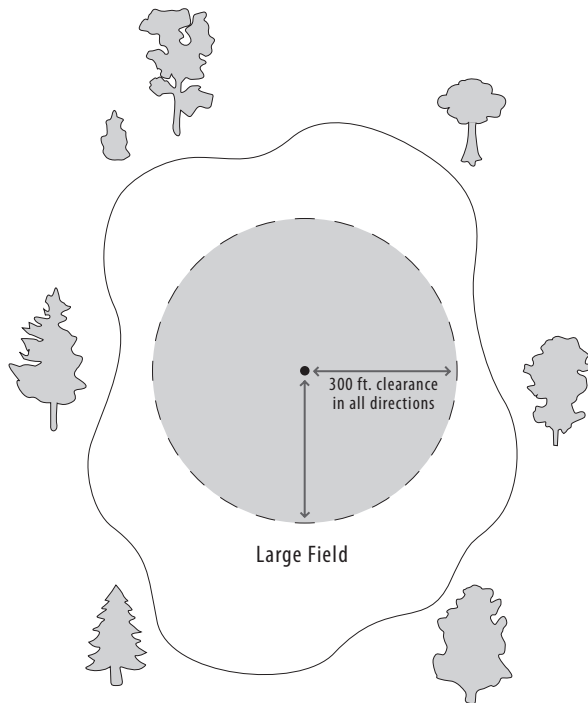

STEP 8: Range Test

A range test requires two people. One person is needed to operate the transmitter and the other is to check and hold the Vector Kite™.

1. Hold the transmitter and have the other person walk about 100 steps away from the transmitter while holding the Vector Kite™. Make sure the person holding the kite has a firm grip on the kite and does not come in contact with the propeller. We recommend firmly holding the rear of the Propulsion Frame
2. Turn the transmitter on.
3. Have the person plug in the battery to the Vector Kite™.
4. Pull the throttle (left stick) all the way to the backward position. This will arm the throttle.
5. Move the steering controls (right stick) and have the other person observe the Vector Kite™. Make sure the controls operate smoothly. Use the directions in the “CONTROL TEST” section above to test the Vector Power Unit™. Make sure the gimbal moves up and down and from side to side per the diagrams.
6. Signal to the other person you want to test the throttle. *SLIGHTLY* move the throttle stick forward and determine if the throttle is working properly.
7. If all works well, have the person bring the Vector Kite™ back to you to prepare for launch.
8. If controls do not work after the range test, check all connections and batteries. Make sure you are using a fully charged battery for the Vector Kite™ and that you have fresh batteries in the transmitter. Make sure the polarities of all the batteries in the transmitter are correct per the instructions inside the battery hatch.

IF MODEL STILL DOES NOT RANGE TEST CORRECTLY, DO NOT FLY YOUR VECTOR KITE. PLEASE CALL THE PREMIER TOLL FREE CUSTOMER SERVICE NUMBER FOR HELP **1-888-416-0174**.

CAUTION: THE PERSON HOLDING THE VECTOR KITE SHOULD HAVE A FIRM GRIP ON THE KITE. MAKE SURE PROPELLER IS COMPLETELY CLEAR OF BODY AND HAIR.

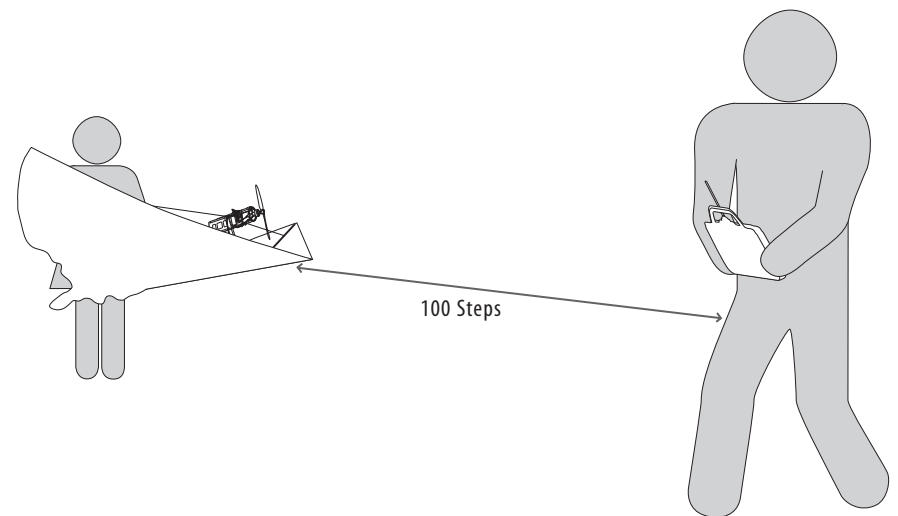

STEP9: Launch

1. For first flights, your Vector Kite™ works best with a hand launch.
2. Hold the Vector Kite™ by the back of the Propulsion Frame with wings level in one hand while holding the transmitter in the other hand.
3. Move the throttle stick forward about $\frac{1}{3}$ to $\frac{1}{2}$ speed and throw the Vector Kite™ forward and slightly up.
4. Immediately get both hands on the transmitter. The throttle stick should be positioned so the Vector Kite™ climbs steadily in the air.
5. Do not attempt to control the Vector Kite™ up or down or left or right (right stick on controls) until the Vector Kite™ is at least 60 feet high in the air.

IMPORTANT TIPS FOR LAUNCH:

1. As discussed earlier, you should have your first flights with no wind. However if there is a slight wind, *ALWAYS LAUNCH INTO THE WIND.*
2. *WHEN LAUNCHING, MAKE SURE THE SPINNING PROPELLER IS COMPLETELY AWAY FROM YOUR HAIR, HEAD, HANDS OR ANY PART OF YOUR BODY. INJURY IS VERY POSSIBLE WITH EVEN THE SLIGHTEST PROPELLER CONTACT.*

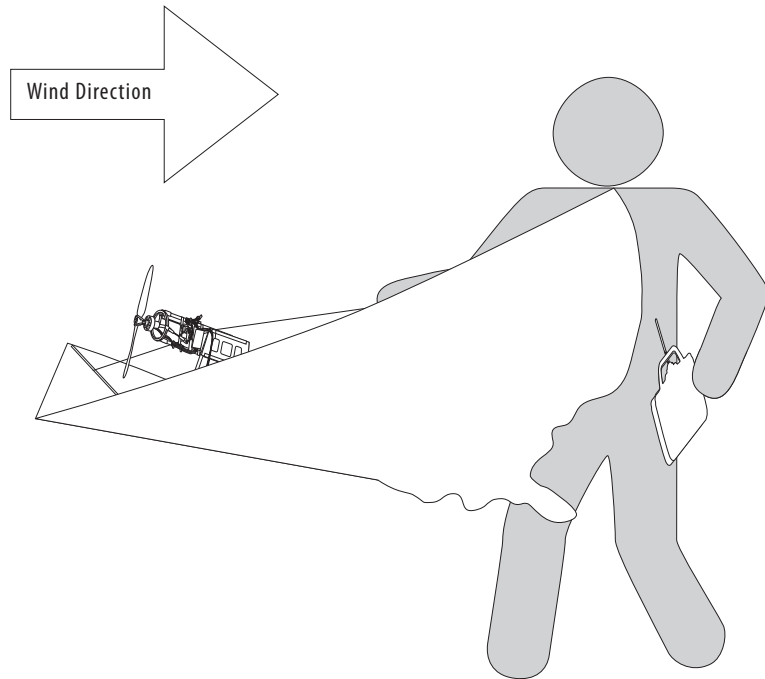

STEP 10: Flying

1. After launching, allow the Vector Kite™ to climb up to at least 60 feet. As the Vector Kite™ climbs you may need to make slight right or left control adjustments to fly straight into the wind.
2. Once you have reached sufficient altitude you may turn the Vector Kite™. Turning is accomplished by a slight push of the control stick either left or right.
3. It is important to note that the Vector Thrust Power Unit™ has a very wide range of control. The most common mistake for beginners is over controlling the Power Unit. Only make slight stick movements at first.
4. Your Vector Kite™ is capable of very radical maneuvers; however it should be the goal of the beginner to simply launch the kite, fly in gentle circles and land the kite near the pilot. This should be practiced many times before aerobatics are attempted.

GENERAL CONTROL TIPS:

1. Keep in mind that vector thrust maneuvers kites in a different manner than traditional moving control surfaces such as ailerons, rudders and elevators. Vector thrust works by directing the driving force of the propeller to the direction you want the kite to go. In light of this it is important to realize that without some throttle input, the Vector Kite™ can not be controlled.
2. Many beginner flyers have the problem concerning which way to turn as the kite is going away from you (simple right and left turns) and coming toward you (left and right is opposite of stick). Although correct "coming and going" turns become second nature with a little experience, here is a good tip: while flying, pretend you are seated right at the tail of the kite and it should be easier making a good judgment about which way to turn. Made a mistake? No problem, just make the correction in the air – kites are slow and usually easy to correct.
3. At the beginning, keep the Vector Kite™ flying in front of you in the field. Try to avoid flying the kite overhead and having to frequently turn your whole body around in circles.

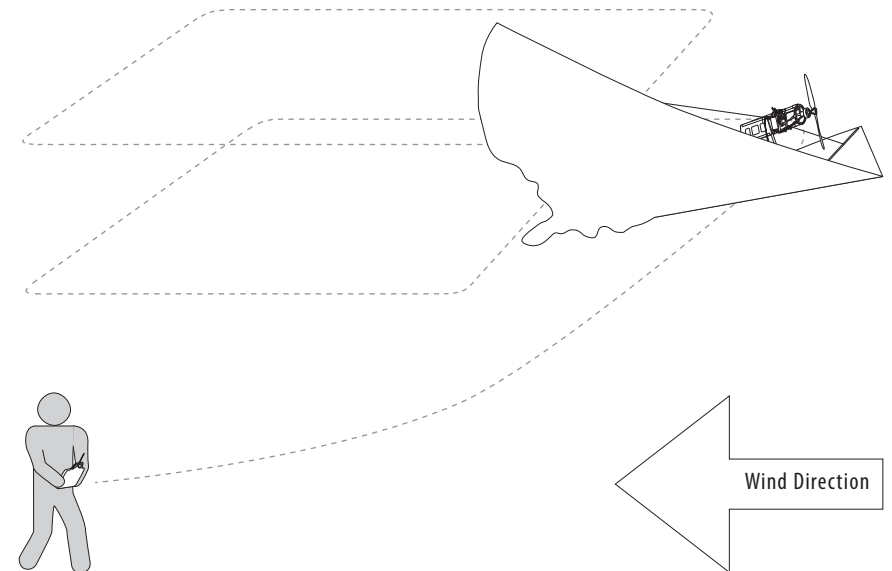

STEP 10: Flying

GENERAL CONTROL TIPS CONTINUED:

4. You may shut off the engine in mid flight however you must remember that to turn the Vector Kite™ in any direction you must power up the motor to direct some amount of thrust in the direction you want to make a turn. Control can only be asserted on the kite if the motor power is on. Keep in mind the more power and the more stick "throw" to the transmitter, the faster and more forceful the reaction of the kite.
5. Start with only small control inputs and work your way up to greater control input as you gain experience.
6. It is also possible to turn the motor off, position the desired thrust direction and then give a "burst" of power to re-direction the kite.
7. Faster turns are also possible by giving the gimbal a slight "up" vector thrust on the control stick while moving the stick to the direction of the turn.
8. **STRATEGY FOR ENCOUNTERING UNFORESEEN WIND:** Steer the Vector Kite™ into the wind. Keep the nose into the wind by using "left-right" thrust controls. Once headed into the wind, use "downward" vector thrust by pushing the control stick forward to help maintain control and pitch of the kite. With practice, Vector Kites™ can advance forward in moderate headwinds.

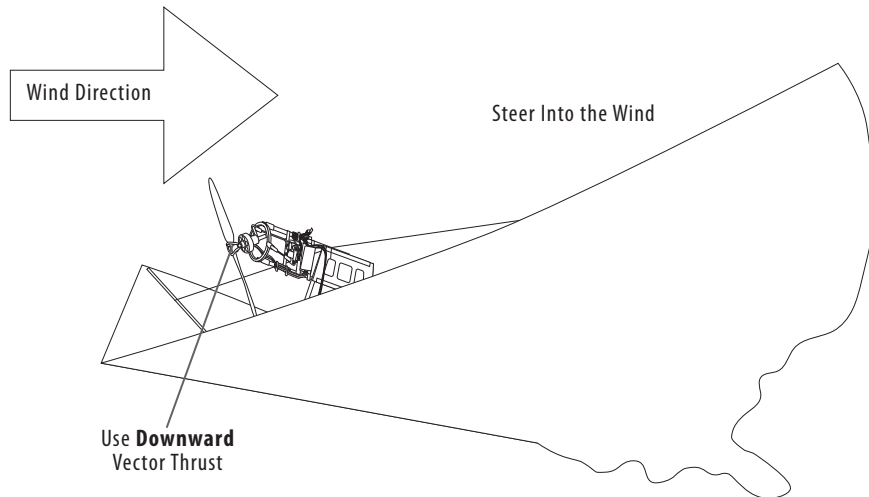

9. FOR THE FASTEST DESCENT IN AN EMERGENCY: Use full downward thrust in combination with a hard turn. Level off when the kite is close to the ground.
10. Keep in mind that the wind can be stronger at higher altitudes. Be careful when ascending.
11. Remember, up/down (*pitch*) and left/right (*yaw*) control can all be used in any combination for the desired maneuver. Focus first on left/right control until you experiment with pitch control.
12. Remember, the beauty of vector thrust is that it does not rely on airspeed. It is a completely new concept for kites and most aircraft. Even if the kite stalls or stops in the air, you can still power it right and left or up and down or in any pitch or yaw combination. As you gain experience, you will undoubtedly discover new maneuvers never seen before. You are a pioneer pilot in the new world of Vector Kiting™!

STEP 11: Trim Adjustments

1. In a zero wind condition and with the control stick in neutral, look carefully as the Vector Kite™ is flying and see whether it has a tendency to go right or left.
2. If you wish, most transmitters are equipped with right/left trim controls to compensate for minor variations or personal preferences in flight control. If you find your kite is favoring the right more than desired, simply adjust trim to the left until straight flight is achieved with the control stick in neutral position. If the kite is favoring toward a left flight path simply trim to the right. Only try trimming in small increments.

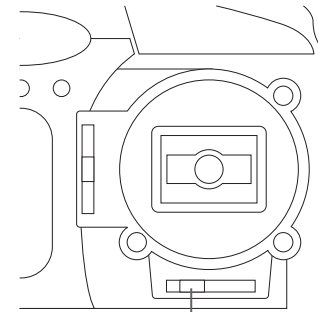

If kite is favoring the right,
adjust trim to the left

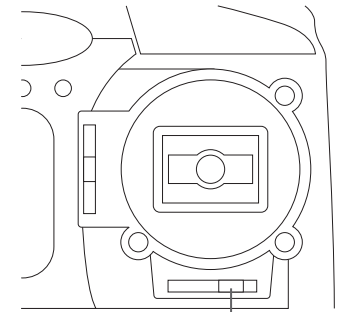

If kite is favoring the left,
adjust trim to the right

3. Most transmitters are also equipped with up/down trim controls. These should only be used after experience flying the Vector Kite™. They are included to make minor pitch adjustments depending on personal flight preferences. If you are an advanced flyer and would like more climb you may try adjusting the trim to make the gimbal direct more upward thrust. A little more upward thrust can also be used by advanced flyers for slower indoor flying. If you are an advanced pilot and are flying in slight breezes, you may find a little downward thrust trim helpful. The best is to become thoroughly familiar with Vector Flying before pitch trim adjustments are made.

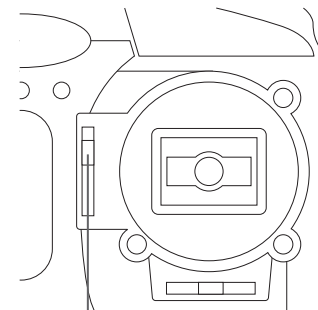

For more upward thrust,
adjust trim up

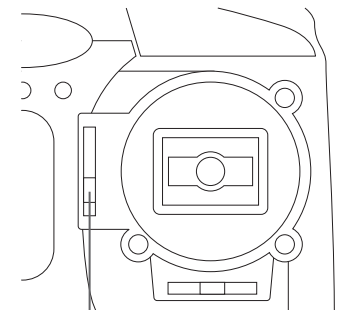

For more downward thrust,
adjust trim down

STEP 12: Throttle and ESC

1. The throttle stick (left stick on transmitter) is one of the most important controls to achieve climbing, descending and level flight.
2. Once your Vector Kite™ has achieved a good altitude, practice slightly pulling back on the throttle stick to the point that the kite descends. As the kite descends, try slightly increasing throttle and try and keep the kite flying level.
3. Make it a goal to achieve level flight with your Vector Kite™ before attempting aerobatics or radical maneuvers.
4. Please note your Vector Power Unit™ is equipped with a powerful custom designed 16 pole brushless motor. Although it weighs only 26 grams, it has about 800 grams of thrust with the matching propeller, battery and ESC. The ESC is a sophisticated device that controls the brushless motor's speed and power usage. For the advanced hobbyist, Premier RC has available for download a full set of instructions for the ESC that includes specifications and programming features. These instructions can be found at www.premierRC.com. Premier RC does not recommend any sort of re-programming of the ESC for beginner flyers however, advanced hobbyists may find the full ESC instructions useful.

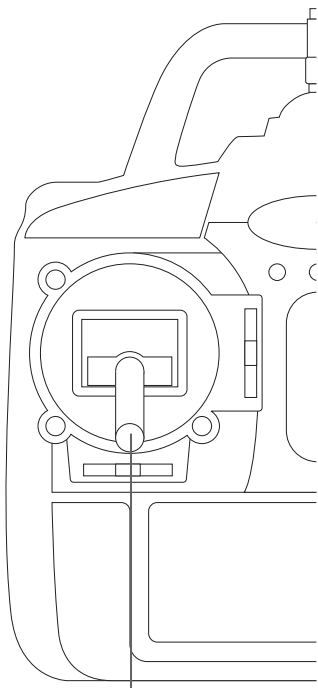

Throttle
Power 'Off'

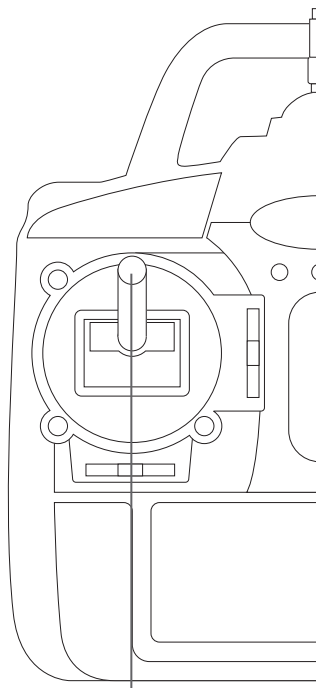

Maximum
Throttle Power

STEP 13: Landing

1. On your first flights, practice cutting the throttle down to about ½ or less and making a controlled descent.
2. As the Vector Kite™ descends under less power, steer the kite back to you. As the kite gets close to the ground, simply cut power and it will gently glide down.
3. For more advanced landings, you may “flair” the kite just before it lands. A flair is accomplished by giving the kite a burst of “up” vector thrust just before the kite comes down to the ground. This maneuver makes for a gentler nose up landing.

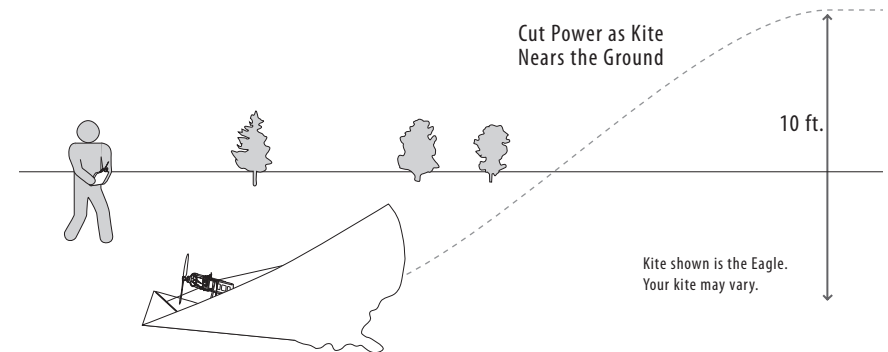

LANDING TIP:

It is important to note that if you lose all battery power on the Vector Power Unit™ you also lose the ability to steer. A de-powered Vector Kite™ is no problem as long as it is free from obstacles to land. Thus on first flights, choose a large field and keep close to the landing zone. A de-powered kite simply floats gently down to the ground.

WHEN YOU ARE AT FULL THROTTLE AND CAN NOT CLIMB ANYMORE, IT IS TIME TO STEER BACK TO A SUITABLE LANDING ZONE. This means you are running out of power. The ESC is also programmed to reduce power when the battery is low. Pilots will often sense this as a “surge” or sudden power drop while flying. Even though you are running low on power, you still have enough power to steer. Use your last bit of power wisely to steer back to the landing zone. Depending on conditions, you may only have a half minute or less of effective steering power left. For power conservation, use short bursts of directed vector thrust to coax the nose of the kite to the direction you want it to go.

EMERGENCY LANDING TIP FOR WIND ENCOUNTERS:

Although beginners should not attempt to fly their Vector Kite™ in any sort of wind, you may find yourself at some point encountering an unforeseen breeze. As soon as you realize you are in a head or tail wind, immediately turn the kite's nose into the wind and head directly into the wind. Give the Power Unit downward thrust and while steering the nose into the wind see if you can move forward and descend. If you are headed into the wind with full downward thrust and your kite begins to climb because you are being overrun by the breeze, POINT THE VECTOR THRUST DOWN AND GIVE THE POWER UNIT A HARD TURN INPUT EITHER RIGHT OR LEFT. This maneuver will put the kite in a spiraling dive downward toward the ground. You will still lose some position if the wind is strong but at least your kite will be coming down. Level the kite off as it gets close to the ground and land.

STEP 14: Center of Gravity Adjustments

1. Your Vector Kite™ is equipped with a unique Velcro panel that allows minor adjustments to the center of gravity of your kite.
2. For your first flights, simply place the battery in the middle of the panel.
3. If you would like to make your Vector Kite™ more nose heavy, move the battery toward the front of the panel. Usually a heavier nose is best if the pilot is encountering a slight breeze.
4. If you would like to make your Vector Kite™ more “stalled” or tail heavy, move the battery toward the back of the panel. Sometimes very advanced pilots will fly a little stalled while attempting very slow flight indoors or in zero wind conditions.

NOTE: BEFORE FLYING CHECK TO MAKE SURE THE BATTERY WILL NOT INTERFERE WITH ANY STRUTS.

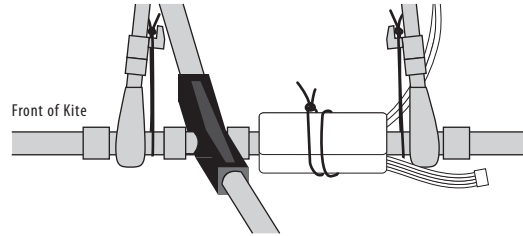

Battery Placement
for **Standard Flying**

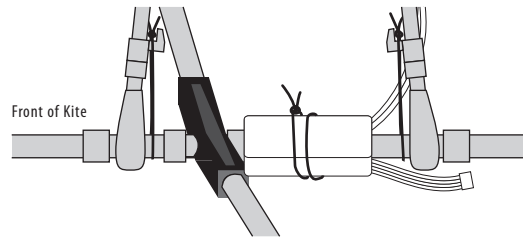

Battery Placement
for **Nose Heavy Flying**

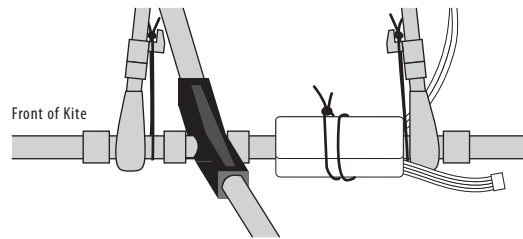

Battery Placement
for **Tail Heavy Flying**

STEP 15: Crash Repair

Your Vector Kite™ is much more resilient to crash damage than traditional RC aircraft. The fiberglass rods, fittings and rip-stop fabric are very durable and have a lot of “give” on most impacts.

Nevertheless, as with all things piloted by man, crashes do occur and some damage can result. Premier RC stocks a complete line of spare parts including rods, fittings, kite sails and power unit parts. If you need a spare part, please visit our website at www.premierRC.com and all parts are available for your Vector Kite™. If you need further help, call our toll free customer service line at **1-888-416-0174**.

WARNINGS AND SAFETY:

In all your flight endeavors, safety must come first! Please read your instructions and all warnings carefully. Your Vector Kite™ is capable of creating serious injury to you and others if you do not read and follow the warnings and directions carefully.

Your Vector Kite™ is not a toy. It should only be flown by adults or under strict adult supervision for ages 15 and under.

Keep the propeller away from all parts of your body. Keep the propeller away from all parts of your body even if it is not spinning! Do not let hair or loose clothing get close to the propeller especially during launch because entanglement could cause injury.

Do not fly your Vector Kite™ in windy conditions. In windy conditions it is very possible to lose control of your Vector Kite™ and cause serious injury.

Never fly your Vector Kite™ near or over people, highways, roads, houses, buildings, vehicles, train tracks, power lines, hard surfaces, water or trees.

Never attempt to catch a Vector Kite™ while flying or landing because both the spinning propeller and moving kite could cause injury.

Use only a battery charger intended for the Lithium Polymer batteries that come with the Vector Power Unit™. **NEVER, NEVER, NEVER** leave the charger unattended while charging the battery. **ALWAYS** place the battery and charger on a fireproof surface such as in a ceramic or metal pot and on a concrete surface. The potential for a damaged, defective or improperly charged battery to catch fire is very real.

Never cut into a battery. Never use a battery that looks damaged from a crash. Never use a battery that looks swollen. Do not use a battery that has damage to the wire insulation. Never intentionally short circuit a battery. **READ ALL BATTERY WARNINGS STATED EARLIER IN THESE INSTRUCTIONS.**

Always hold a Vector Kite™ firmly when the battery is plugged into the Vector Power Unit™ to keep body parts away from the propeller.

Always turn the transmitter on first before plugging in the Vector Power Unit™.

Always unplug the Vector Power Unit™ first before turning off the transmitter.

Please use common sense. Fly Safe.

THE ACADEMY OF MODEL AERONAUTICS:

To learn more about the exciting world of remote control flight we highly recommend you join the Academy of Model Aeronautics. Please visit their website at www.modelaircraft.org

THE AMERICAN KITEFLIERS ASSOCIATION:

To learn about the exciting world of kites and kite flying we highly recommend you join the American Kite Flyers Association. Please visit their website at www.aka.kite.org

WARRANTY AND CUSTOMER SERVICE:

Due to the unforeseen events that encompass the nature of remote control flying devices, Premier RC can not extend the warranty beyond the initial preflight testing. It is up to the user to carefully check the product's operation and parts through the control tests and range tests listed above *before* your first flight. Any damage incurred during launching, flying, landing or crashing is not covered under the warranty.

WARRANTY:

Premier RC guarantees this product to be free of defects in material and workmanship for the date of one year after the purchase of the product. If you discover any defects during initial pre-flight testing please call our Customer Service number at **1-888-416-0174** to report the problem. If directed to do so, you will be given an RA (return authorization number) to return the product. Premier RC will determine the problem and at our discretion repair or replace the product. Warranty coverage does not extend to products that have been flown.

REPLACEMENT & OPTIONAL PARTS:

Propulsion Unit Parts:		Kite Parts:	
10101	840 Vector Power Unit	10381	Butterfly Propulsion Frame with Tension Lines
10364	840 Frame & Gimbal Only	10382	Cross Strut
10202	V580 High Performance Brushless Motor	10383	Spine
10203	20 Amp ESC	10384	Tail Struts with Tension Line
10205	3 cell, 12.6 (max) volt 1050mAh LiPo Battery	For parts ordering please visit our website at www.PremierRC.com	
10207	Battery Charger		
10286	Battery Charger Power Supply		
10209	GWS 8040 Propeller		
10211	Prop-saver (includes o-ring)		
10264	O-ring		
10341	High Torque 5810 MG Metal Gear Servo		
10213	Servo Arm Set		
10342	840 Servo Push Rods		
10214	2.4MHz Four Channel Transmitter and Receiver		
10215	2.4MHz Four Channel Receiver		
10218	Premier Transmitter Flying Strap		

Parts List

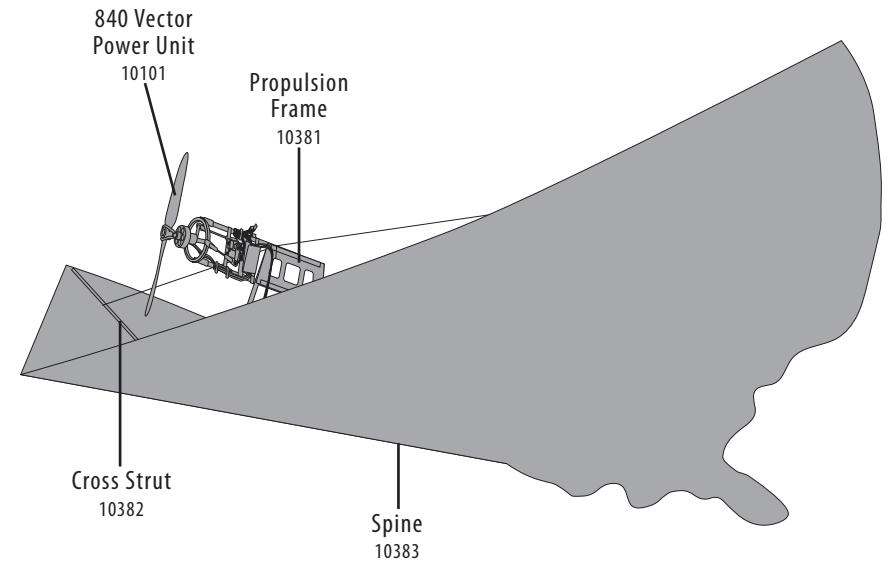

840 Vector Power Unit Parts List

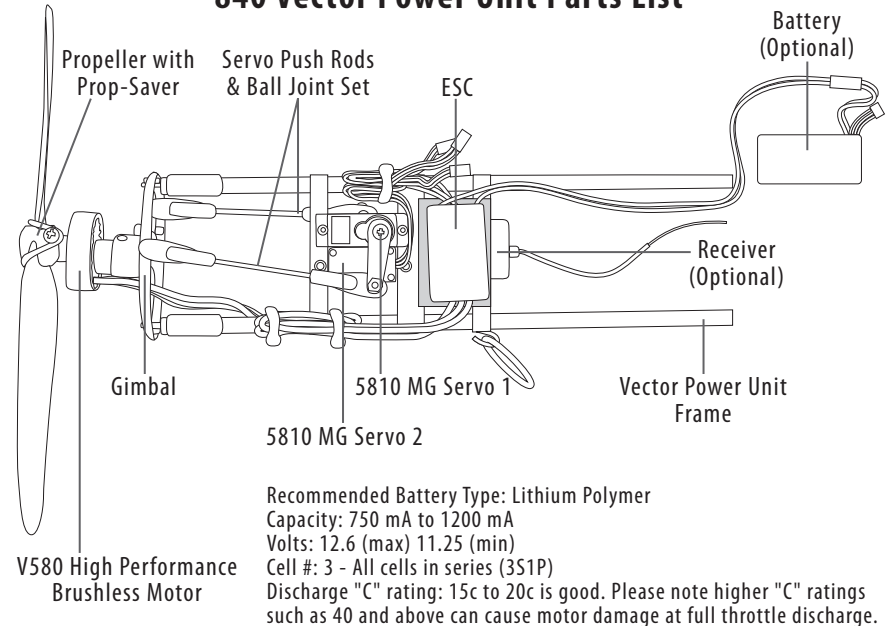

Parts can be purchased at www.premierRC.com

Pilot's Log

Date	Place	Duration	Notes

Date	Place	Duration	Notes

Pilot's Log

Date	Place	Duration	Notes

Date	Place	Duration	Notes



PremierRC

5200 Lawrence Place

Hyattsville, Maryland 20781, USA

Toll Free: 1-888-416-0174

Phone: 301-277-3888

Fax: 301-277-3323